

LF310 Datasheet

LOW-FLOW PRESSURE REGULATOR



Gas Liquid |
 Diaphragm Piston |
 Self-Venting Non-Venting |
 Max Inlet: 414 bar (6,000 psi) |
 Max Outlet: 35 bar (510 psi) |
 Cv 0.06



INTRODUCING THE LF310...

The LF310 is a single-stage diaphragm-sensed pressure regulator for applications that require higher supply pressures in addition to an extended life cycle.

Based on the LF300, with its long-lasting Inconel® X750 diaphragm, the LF310 also offers a 'solid disk' seat design which is more robust for aggressive or high temperature applications.

SPECIFICATION

Max. Rated Inlet Pressure	414 bar (6,000 psi)
Outlet Ranges	Up to 35 bar (510 psi)
Design Proof Pressure	150% max. working pressure
Seat Leakage	In accordance with ANSI/FCI 70-3
Weight	0.9kg (2lbs)

STANDARD MATERIALS OF CONSTRUCTION

PART	MATERIALS
Body and Bonnet	AISI 316 / 316L Stainless Steel (UNS S31600 / S31603)
Main Valve Pin	AISI 316 / 316L Stainless Steel (UNS S31600 / S31603)
Soft Seat	PEEK™ or PCTFE
Valve Spring	Inconel® X750
Diaphragm	Inconel® X750
Handwheel	Nylon
'O'-Ring Seals	FKM / FPM
Loading Spring	AISI 302 Stainless Steel (UNS S30200)
Filter	40 Microns

FEATURES AND BENEFITS

1 INCONEL® X750 DIAPHRAGM

For ultimate strength and reliability on clean or corrosive applications.

2 316SS THREADED BONNET

For panel mounting option as standard.

3 40 MICRON INLET FILTER

First stage soft seat protection from system contamination.

4 SOLID DISK SEAT DESIGN

Robust design enabling higher inlet pressures of up to 414 bar (6,000 psi).

Product availability and specifications contained herein are subject to change without notice. Consult local distributor or factory for potential revisions and/or service related issues. Pressure Tech Ltd support with product selection recommendations only - it is the users responsibility to ensure the product is suitable for their specific application requirements.



DESIGNED AND BUILT IN THE UK

PRESSURE TECH LTD

Unit 24, Graphite Way, Hadfield, Glossop, Derbyshire, UK, SK13 1QH
 T +44 (0)1457 899 307
 E info@pressure-tech.com
 W www.pressure-tech.com

131218

PAGE:
1 OF 4

LF310 Datasheet

LOW-FLOW PRESSURE REGULATOR



Gas
 Liquid
 Diaphragm
 Piston
 Self-Venting
 Non-Venting
 Max Inlet: 414 bar (6,000 psi)
 Max Outlet: 35 bar (510 psi)
 Cv 0.06

DRAWINGS AND INSTALLATION DIMENSIONS

Dimensions shown for 1/4" NPT option - please contact the office for additional connection options.

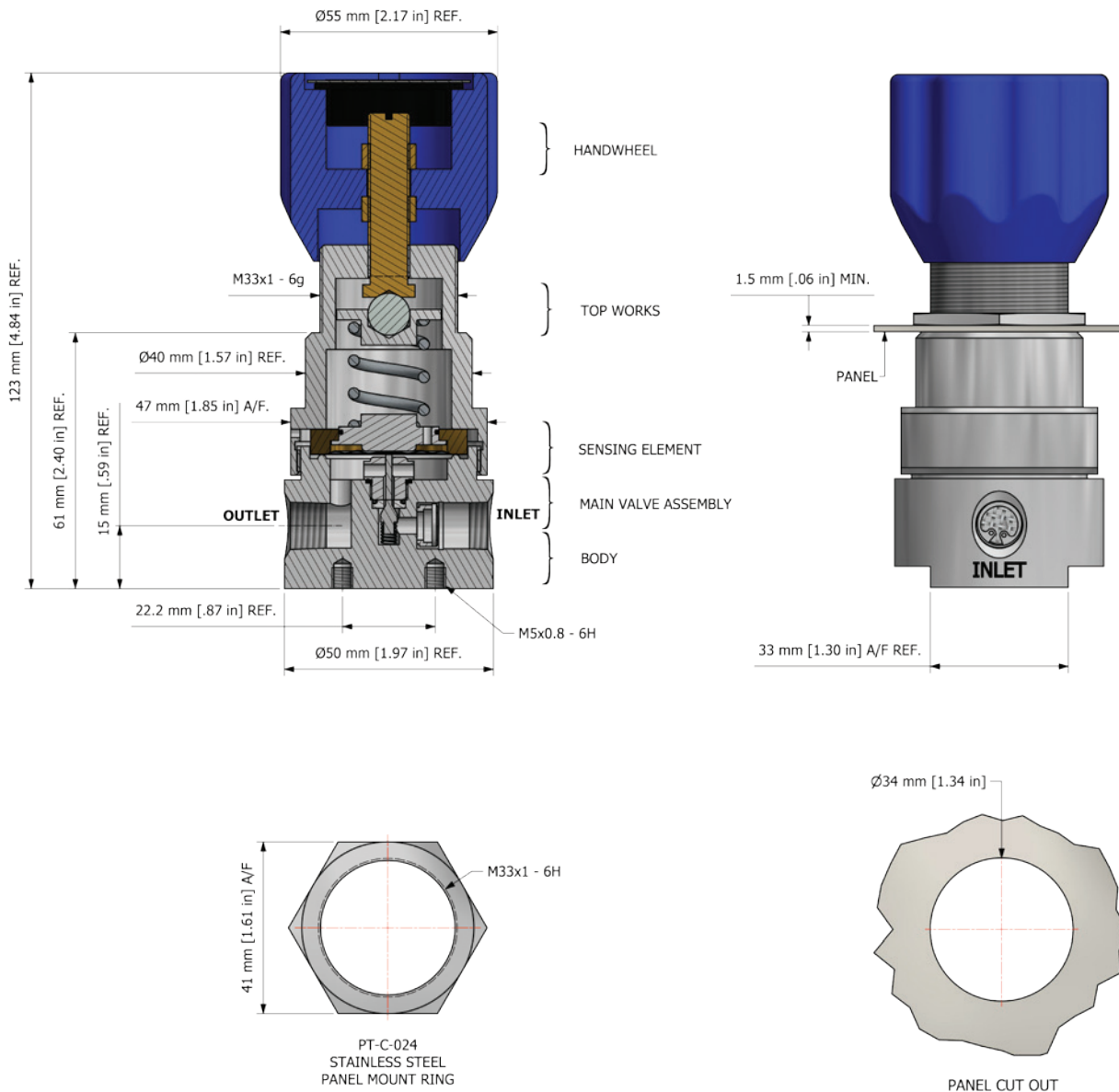

Note:
All gauge ports are 1/4" NPT as standard.

Product availability and specifications contained herein are subject to change without notice. Consult local distributor or factory for potential revisions and/or service related issues. Pressure Tech Ltd support with product selection recommendations only - it is the users responsibility to ensure the product is suitable for their specific application requirements.



DESIGNED AND BUILT IN THE UK

PRESSURE TECH LTD
 Unit 24, Graphite Way, Hadfield, Glossop, Derbyshire, UK, SK13 1QH
 T +44 (0)1457 899 307
 E info@pressure-tech.com
 W www.pressure-tech.com

131218

PAGE:
2 OF 4

LF310 Datasheet

LOW-FLOW PRESSURE REGULATOR



Gas Liquid | Diaphragm Piston | Self-Venting Non-Venting | Max Inlet: 414 bar (6,000 psi) | Max Outlet: 35 bar (510 psi) | Cv 0.06

FLOW CURVE

Please contact the office for further information.

PORTING CONFIGURATIONS

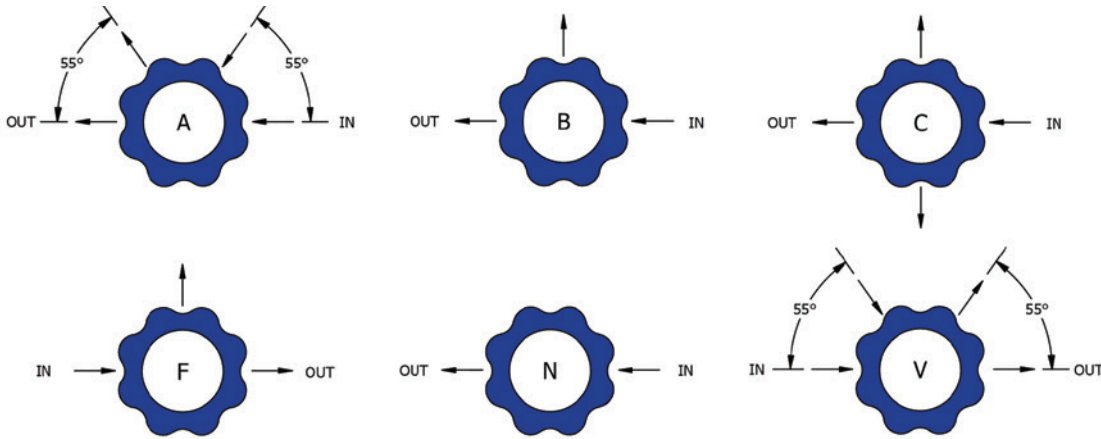

Note:

Additional porting configurations are available - please contact the office for further information.

Product availability and specifications contained herein are subject to change without notice. Consult local distributor or factory for potential revisions and/or service related issues. Pressure Tech Ltd support with product selection recommendations only - it is the users responsibility to ensure the product is suitable for their specific application requirements.



DESIGNED AND BUILT IN THE UK

PRESSURE TECH LTD

Unit 24, Graphite Way, Hadfield, Glossop, Derbyshire, UK, SK13 1QH

T +44 (0)1457 899 307

E info@pressure-tech.com

W www.pressure-tech.com

131218

PAGE:
3 OF 4

LF310 Datasheet

LOW-FLOW PRESSURE REGULATOR



Gas Liquid | Diaphragm Piston | Self-Venting Non-Venting | Max Inlet: 414 bar (6,000 psi) | Max Outlet: 35 bar (510 psi) | Cv 0.06

ORDERING INFORMATION

To build a Pressure Tech part number, simply combine the characters identified below in sequence:

LF310 - 06 - S - 35 - P - N - XXX	
REGULATOR MODEL/SERIES LF310 – Single-Stage Pressure Regulator - Diaphragm-Sensed	MODIFICATIONS* Please contact the office for further information.
CV VALUE 06 – 0.06 15 – 0.15 (max. inlet 50 bar / 725 psi)	PORTING CONFIGURATION N - No gauge ports Please refer to page 3 for porting configuration options.
BODY MATERIAL** S – AISI 316 / 316L Stainless Steel (UNS S31600 / S31603) B – HT Brass H – Hastelloy® (UNS N10276)	SEAT MATERIAL** T – PTFE (20 bar / 290 psi inlet) F – FEP (50 bar / 725 psi inlet) K – PCTFE (300 bar / 4,350 psi inlet) P – PEEK™ (414 bar / 6,000 psi inlet)
CONTROL PRESSURE 04 – Up to 4 bar (60 psi) 10 – Up to 10 bar (145 psi) 20 – Up to 20 bar (290 psi) 35 – Up to 35 bar (510 psi)	

OPTIONAL EXTRAS		
	PART NUMBER	DESCRIPTION
Service Kit	SRK-LF310-06-U-K-M2-V	PCTFE seat and FKM/FPM seals
Service Kit	SRK-LF310-06-U-P-M2-V	PEEK™ seat and FKM/FPM seals
Panel Mounting Ring	PT-C-024	-

Note:
Ancillary equipment and additional Service Kit options also available

TRADEMARKS: PEEK™ is a trademark of Victrex PLC
 Inconel® is a registered trademark of Inco Alloys International
 Hastelloy® is a registered trademark of Haynes International, Inc

* Where applicable
 ** Other materials may be available - please contact the office

Product availability and specifications contained herein are subject to change without notice. Consult local distributor or factory for potential revisions and/or service related issues. Pressure Tech Ltd support with product selection recommendations only - it is the users responsibility to ensure the product is suitable for their specific application requirements.



DESIGNED AND BUILT IN THE UK

PRESSURE TECH LTD
 Unit 24, Graphite Way, Hadfield, Glossop, Derbyshire, UK, SK13 1QH
 T +44 (0)1457 899 307
 E info@pressure-tech.com
 W www.pressure-tech.com

131218

PAGE: 4 OF 4