

# MF-231 Datasheet

## MEDIUM-FLOW PRESSURE REGULATOR



Gas  
  Liquid  
  Diaphragm  
  Piston  
  Self-Venting  
  Non-Venting  
 Max Inlet: 230bar (3,350psi)  
 Max Outlet: 100bar (1,450psi)  
 Cv 1.0



Image for illustration purposes only

### INTRODUCING THE MF-231...

The MF-231 is a versatile and economical piston-sensed medium-flow pressure regulator for gas applications.

The MF-231 features a balanced main valve design which minimises load on the seat and provides stable pressure control under decaying inlet conditions. Additionally, servicing is simplified with easy access to the seat cartridge from the base of the regulator.

### SPECIFICATION

Max Rated Inlet Pressure	230bar (3,350psi)
Outlet Ranges	Up to 100bar (1,450psi)
Design Proof Pressure	150% max WP
Seat Leakage	In accordance with ANSI/FCI 70-3
Weight	1.7kg (3.7lbs)

### STANDARD MATERIALS OF CONSTRUCTION

PART	MATERIALS
Body and Bonnet	AISI 316 / 316L Stainless Steel (UNS S31600 / S31603)
Main Valve Pin	AISI 316 / 316L Stainless Steel (UNS S31600 / S31603)
Soft Seat	PCTFE
Valve Spring	Inconel® X750
Piston	AISI 316 / 316L Stainless Steel (UNS S31600 / S31603)
Handwheel	Nylon
'O'-Ring Seals	FKM / FPM
Loading Spring	AISI 302 Stainless Steel (UNS S30200)

### FEATURES AND BENEFITS

#### 1 PISTON SENSING ELEMENT

Perfect for use in challenging conditions.

#### 2 BALANCED MAIN VALVE DESIGN

Minimises droop across the flow range.

#### 3 LOW DECAYING PRESSURE EFFECT

Stable outlet pressure under varying inlet conditions.

#### 4 MAIN VALVE BOTTOM ENTRY

Simplified servicing through base of regulator.

Product availability and specifications contained herein are subject to change without notice. Consult local distributor or factory for potential revisions and/or service related issues. Pressure Tech Ltd support with product selection recommendations only - it is the users responsibility to ensure the product is suitable for their specific application requirements.



DESIGNED AND BUILT IN THE UK

**PRESSURE TECH LTD**  
 Unit 24, Graphite Way, Hadfield, Glossop, Derbyshire, UK, SK13 1QH  
 T +44 (0)1457 899 307  
 E info@pressure-tech.com  
 W www.pressure-tech.com

070917

PAGE:  
1 OF 4

# MF-231 Datasheet

MEDIUM-FLOW PRESSURE REGULATOR



● Gas ● Liquid | 
 ● Diaphragm ● Piston | 
 ● Self-Venting ● Non-Venting | 
 Max Inlet: 230bar (3,350psi) | 
 Max Outlet: 100bar (1,450psi) | 
 Cv 1.0

## DRAWINGS AND INSTALLATION DIMENSIONS

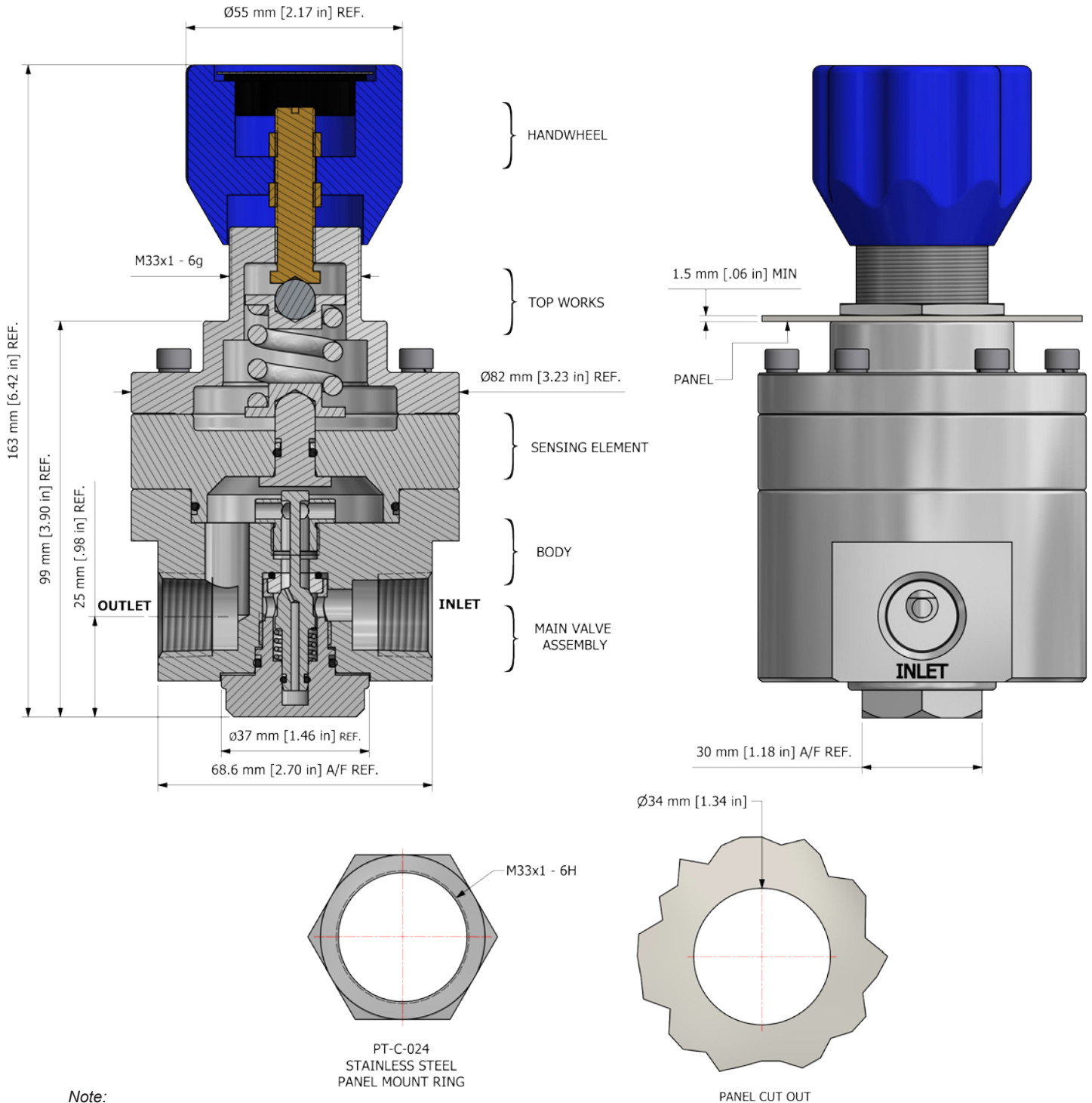

**Note:**  
All gauge ports are 1/4" NPT as standard.

Product availability and specifications contained herein are subject to change without notice. Consult local distributor or factory for potential revisions and/or service related issues. Pressure Tech Ltd support with product selection recommendations only - it is the users responsibility to ensure the product is suitable for their specific application requirements.



DESIGNED AND BUILT IN THE UK

**PRESSURE TECH LTD**  
 Unit 24, Graphite Way, Hadfield, Glossop, Derbyshire, UK, SK13 1QH  
 T +44 (0)1457 899 307  
 E info@pressure-tech.com  
 W www.pressure-tech.com

070917

PAGE:  
2 OF 4

# MF-231 Datasheet

MEDIUM-FLOW PRESSURE REGULATOR



Gas  Liquid |  Diaphragm  Piston |  Self-Venting  Non-Venting | Max Inlet: 230bar (3,350psi) | Max Outlet: 100bar (1,450psi) | Cv 1.0

## FLOW CURVE

Please contact the office for further information.

## PORTING CONFIGURATIONS

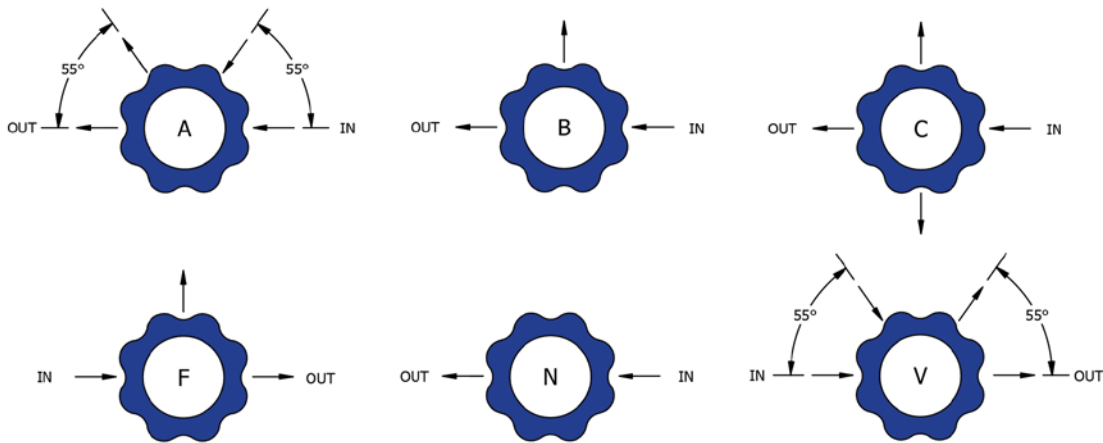

**Note:**

Additional porting configurations are available - please contact the office for further information.

Product availability and specifications contained herein are subject to change without notice. Consult local distributor or factory for potential revisions and/or service related issues. Pressure Tech Ltd support with product selection recommendations only - it is the users responsibility to ensure the product is suitable for their specific application requirements.



DESIGNED AND BUILT IN THE UK

**PRESSURE TECH LTD**  
Unit 24, Graphite Way, Hadfield, Glossop, Derbyshire, UK, SK13 1QH  
T +44 (0)1457 899 307  
E info@pressure-tech.com  
W www.pressure-tech.com

070917

PAGE:  
3 OF 4

# MF-231 Datasheet

## MEDIUM-FLOW PRESSURE REGULATOR



Gas  
  Liquid  
  Diaphragm  
  Piston  
  Self-Venting  
  Non-Venting  
 Max Inlet: 230bar (3,350psi)  
 Max Outlet: 100bar (1,450psi)  
 Cv 1.0

### ORDERING INFORMATION

To build a Pressure Tech part number, simply combine the characters identified below in sequence:

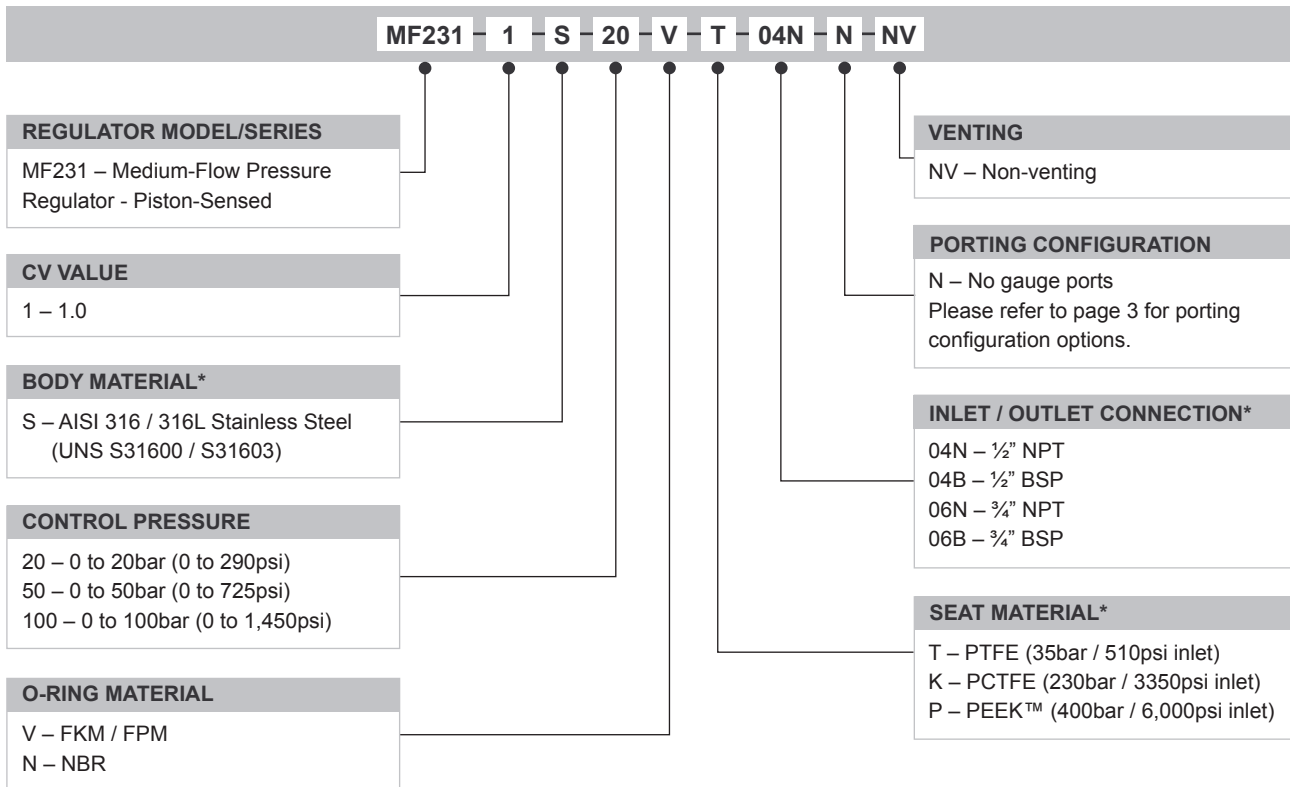

OPTIONAL EXTRAS		
	PART NUMBER	DESCRIPTION
Service Kit	SRK-MF231-1-B...	Various options available
Panel Mount Ring	PT-C-024	-

*Note:*  
Ancillary equipment also available

**TRADEMARKS:** PEEK™ is a trademark of Victrex PLC  
 Inconel® is a registered trademark of Inco Alloys International

\* Other materials may be available - please contact the office

Product availability and specifications contained herein are subject to change without notice. Consult local distributor or factory for potential revisions and/or service related issues. Pressure Tech Ltd support with product selection recommendations only - it is the users responsibility to ensure the product is suitable for their specific application requirements.



DESIGNED AND BUILT IN THE UK

**PRESSURE TECH LTD**  
 Unit 24, Graphite Way, Hadfield, Glossop, Derbyshire, UK, SK13 1QH  
 T +44 (0)1457 899 307  
 E info@pressure-tech.com  
 W www.pressure-tech.com

070917

PAGE:  
4 OF 4